

CWS COMMERCIAL WRAP (9")



WARNING/ADVERTENCIA/AVERTISSEMENT

To reduce the risk of electrical shock, fire, or injury to persons; read and follow all warnings and installation instructions before installing. All installation should be performed by a qualified electrician.

Risk of Electric Shock

Ensure power is off before installation or inspection. All wirings are performed in accordance with Electrical Code and local electrical code.

Risk of Fire

Fixtures are rated for use in 120-277V, 50-60Hz protected circuit and 90°C rated supply wire.

Para reducir el riesgo de descarga eléctrica, incendio o lesiones a personas, lea y siga todas las advertencias e instrucciones de instalación antes de realizarla. Toda instalación debe ser efectuada por un electricista cualificado.

Riesgo de descarga eléctrica

Asegúrese de desconectar la corriente antes de la instalación o inspección. Todos los cableados se realizan de acuerdo con el Código Eléctrico y el código eléctrico local.

Riesgo de incendio

Las luminarias están clasificadas para su uso con 120-277 V, circuitos protegidos de 50-60 Hz y cables adecuados para 90 °C.

Lisez et suivez les instructions d'installation et les avertissements avant l'installation. Toute l'installation doit être exécutée par un électricien qualifié, pour réduire les risques de choc électrique, de feu ou de blessures corporelles.

Risque de choc électrique

Assurez-vous que le courant soit coupé avant l'installation ou l'inspection et que tout le câblage soit effectué en conformité avec le code d'électricité et le code local d'électricité.

Risque de feu

Les luminaires sont conçus pour une utilisation de 120 à 277 V, pour un circuit protégé de 50 à 60 Hz et pour une source d'alimentation de 90 °C.

FOR YOUR SAFETY

While performing installations described, gloves, safety glasses or goggles should be worn.

PARA SU SEGURIDAD

Mientras realice las instalaciones descritas, se recomienda el uso de guantes y gafas de seguridad.

POUR VOTRE SÉCURITÉ

Vous devriez porter des gants et des verres de protection lors des installations détaillées.

Install this kit only in the luminaire that have the construction features and dimensions shown in the photographs and/or drawings. Do not make or alter any open holes in an enclosure of wiring or electrical components during kit installation.

To prevent wiring damage or abrasion, do not expose wiring to edges of sheet metal or other sharp objects.

Do not alter, relocate, or remove wiring, lampholders, power supply, or any other electrical component.

SUITABLE FOR DAMP LOCATIONS.

Instale este kit solo en la luminaria que tiene las características de construcción y dimensiones que aparecen en las fotografías y/o dibujos. No realice ni altere los agujeros abiertos en un recinto de cableado ni en cualquier componente eléctrico durante la instalación del kit.

Para evitar daños en el cableado o abrasiones, no exponga el cableado a hojas de metal laminado u otros objetos cortopunzantes.

No altere, reubique o elimine cables, portalámparas, tomacorriente o cualquier otro componente eléctrico.

APTO PARA LUGARES HÚMEDOS.

Installez cet ensemble seulement dans un luminaire qui possède les caractéristiques de construction et les dimensions telles que démontrées sur les photographies et/ou dessins. Ne pas percer de trous ou modifier les trous existants dans un boîtier ou des composants électriques durant l'installation de l'ensemble.

Pour prévenir les dommages ou l'abrasion, ne pas mettre en contact le câblage avec des bords de plaques de metal ou tout autre objet coupant.

Ne pas modifier, délocaliser ou enlever du câblage, des supports de lampes, une source d'alimentation ou tout autre composant électrique.

CONVIENT AUX ENDROITS HUMIDES.

This is important with an uneven wall surface. Silicone all plugs and unused conduit entries. For wet location compliance, fixture must be properly sealed. For moisture seal, apply silicone caulking between the mounting surface and back housing, as well as around the sides of the housing. This is important with uneven wall surface.

Esto es importante con una superficie de pared irregular. Silicona todos los tapones y entradas de conductos no utilizados. Para cumplir con la ubicación húmeda, el accesorio debe estar sellado adecuadamente. Para sellar contra la humedad, aplique sellador de silicona entre la superficie de montaje y la carcasa trasera, así como alrededor de los lados de la carcasa. Esto es importante en caso de paredes con superficies irregulares.

Ceci est important en cas de surface murale inégale. Silicomez tous les bouchons et entrées de conduits inutilisés. Pour être conforme aux emplacements humides, le luminaire doit être correctement scellé. Pour assurer l'étanchéité à l'humidité, appliquez un calfeutrage au silicone entre la surface de montage et l'arrière du boîtier, ainsi que sur les côtés du boîtier. Ceci est important en cas de surface murale inégale.

INSIDE THE BOX

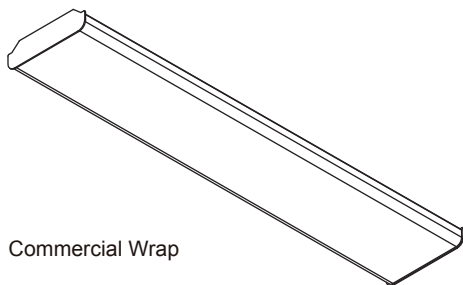

Commercial Wrap

Plusrite USA
2000 S. Grove Ave, Bldg B
Ontario CA 91761

T:909-930-6868
T:888-758-7443
F:909-930-9988

www.naturalled.com

CWS COMMERCIAL WRAP (9")

INSTALLATION/INSTALACIÓN

Disconnect the power before installation.

Desconecte la alimentación antes de la instalación./ Débranchez l'alimentation avant l'installation.

IMPORTANT

READ CAREFULLY BEFORE INSTALLING FIXTURE. RETAIN THESE INSTRUCTIONS FOR FUTURE REFERENCE.

Fixtures must be wired in accordance with the National Electrical Code and all applicable local codes. Proper grounding is required for safety. THIS PRODUCT MUST BE INSTALLED IN ACCORDANCE WITH THE APPLICABLE INSTALLATION CODE BY A PERSON FAMILIAR WITH THE CONSTRUCTION AND OPERATION OF THE PRODUCT AND THE HAZARDS INVOLVED.

WARNING: Make certain power is OFF before installing or maintaining fixture. No user serviceable parts inside.

SURFACE MOUNTING

The fixture is suitable for indoor applications for ceiling or wall mounting. Mount to a recessed octagonal junction box as follows:

1. Carefully snap out **Lens** one side at a time from **Housing**.
2. Remove **Screws (2)** from **Reflector** and discard. Squeeze center of **Reflector** and release from **Notches**.
3. Pull supply wires from Junction Box (not supplied) through **Center Access Hole** of **Housing** as shown in Fig. 1. Use appropriate UL approved wire connectors as required by code to make electrical splices to fixture leads.
4. For conduit mounting drill out **End Cap**, connect conduit.
5. Secure **Housing** to junction box or mount **Housing** directly to sturdy surface by using the **Drill Locations** (6 holes for 4 FT fixture, 4 holes for 2 FT) fixture. Use the appropriate mounting hardware for the mounting surface.
6. Once connections are made push all wires behind the **Reflector**.
7. Replace **Reflector**. Be careful not to pinch wires. Hook **Lens** to one side of **Housing** and Snap **Lens** into place as shown in Fig. 2.

WARNING: To prevent wiring damage or abrasion, do not expose wiring to edges of sharp objects.

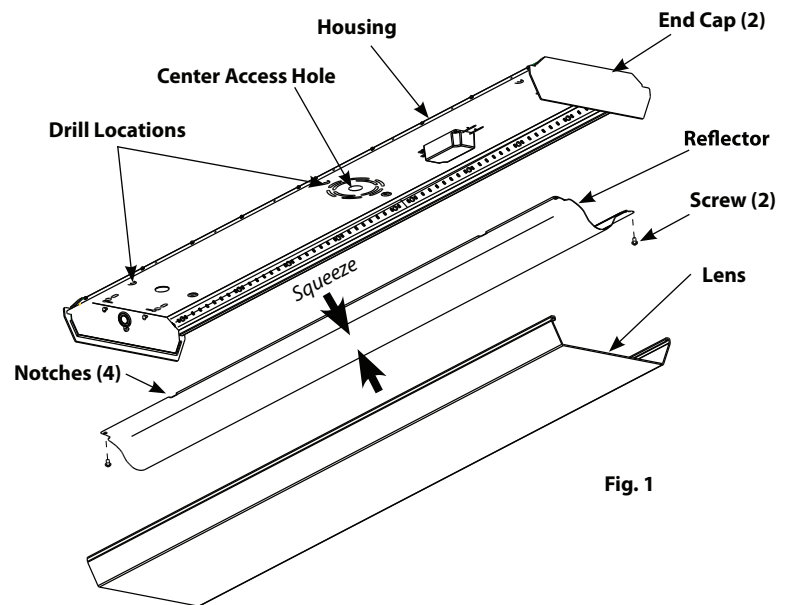

Fig. 1

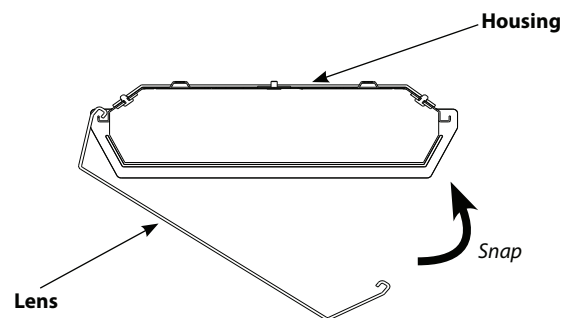

Fig. 2

CWS COMMERCIAL WRAP (9")

INSTALLATION/INSTALACIÓN

INSTALLATION OPTIONS: Mounting Bracket (ordered separately) - Fig. 3

1. Put two fixtures end to end.
2. Secure the bracket with 4 screws provided. See Fig.3

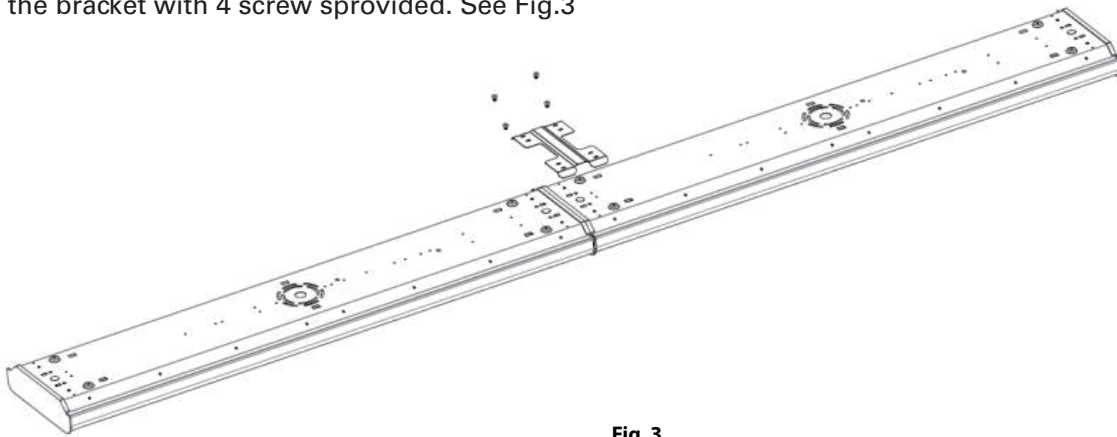

Fig. 3

0-10V DIMMABLE WIRING

Universal voltage driver permits operation at 120V thru 277V, 50 or 60 Hz. For 0-10V Dimming, follow the wiring directions in **Fig. 4**.

- 1.2 Connect the black fixture lead to the LINE supply lead.
 - Connect the white fixture lead to the COMMON supply lead.
 3. Connect the GROUND wire from fixture to supply ground. Do NOT connect the GROUND of the dimming fixture to the output.
 - 4.5 Connect the purple fixture lead to the (V+) DIM lead.
 - .6. Connect the gray fixture lead to the (V-) DIM lead.
- Cap the yellow fixture lead, if present. Do NOT connect.

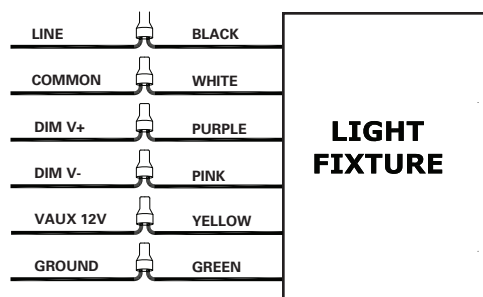

Fig. 4

CLEANING & MAINTENANCE

CAUTION: Be sure fixture temperature is cool enough to touch. Do not clean or maintain while fixture is energized.

1. Clean polycarbonate lens with non-abrasive cleaning solution.
2. Do not open the fixture to clean the LEDs. Do not touch the LEDs.

TROUBLESHOOTING

1. Check that the line voltage at the fixture is correct. Refer to wiring directions.
2. Be sure the fixture is grounded properly.

Note: These instructions do not cover all details or variations in equipment nor do they provide for every possible situation during installation operation or maintenance.